

PHRF REGULATIONS

1. DEFINITIONS

J	Distance perpendicular from foreside of mast line to the point of intersection of the forestay with deck.
I	Height of foretriangle. Measured from deck sheer line abeam the mast to highest point of sail attachment.
P	Luff length of mainsail measured from boom to headboard in its highest position.
E	Foot length of mainsail measured from mast to clew in its most outboard position.
LP	Distance perpendicular from the luff to the clew of the largest jib.
LOA	Length overall of the hull. Note bowsprit and/or boomkin separately.
LWL	Load water line.
BEAM	Maximum beam of the vessel.
DRAFT	Draft of hull. Also include draft with board down if centerboard yacht.
DISPL	Displacement of vessel in pounds without crew, water, fuel or stores aboard.
BAL	Ballast of vessel in pounds. Note any additions or deletions from standard and the location.
CREW WEIGHT	"STD." if to use base boat maximum weight. Otherwise, declare maximum weight desired.
SPL	Spinnaker pole length measured with the pole in its fitting and set in a horizontal position athwartship.
SMW	Spinnaker maximum girth luff to luff. Fold on centerline, measure width and multiply by 2.
SL	Spinnaker luff length.
S. AREA	Symmetrical spinnaker area. Consult your sailmaker.
TPS	Sprit pole length.
SMG	Asymmetric mid-girth.
SF	Asymmetric foot length.
SLU	Asymmetric luff length.
SLE	Asymmetric leach length.
A. AREA	Area of asymmetric spinnaker as calculated by the IACC formula. Consult your sailmaker.
MATERIALS	Construction materials of hull, keel, mast and rudder, eg. fiberglass, lead, iron, aluminum, carbon fiber, etc.

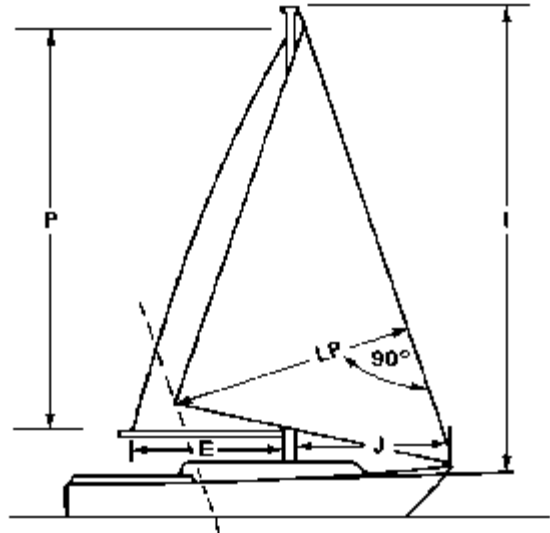

SPIN. GIRTH MEAS.

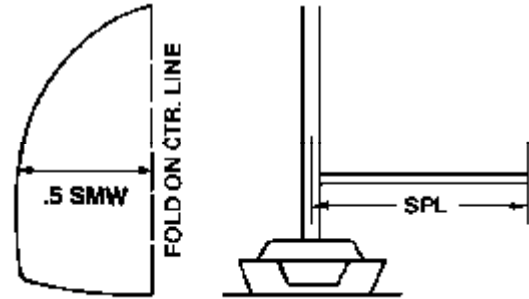

2. HANDICAP ADJUSTMENTS

A. MAST

The effect on performance of changes from standard rig dimensions varies from boat to boat to so great an extent that no rational table of rating changes based on rig size can be formulated. Accordingly, these are treated by the PHRF Committee on a case by case basis. If your boat is one of a class and your rig differs from the standard for that class, you must notify the Committee of that fact. If you have a custom boat and your rig is changed from that described on your rating application, you must notify the Committee of the changes. A "change" refers not only to length, but also to material, weight, wire size, number of spreaders, diameter, etc.

B. PROPULSION

Adjustment is based on type of propeller and its installation.

PROP/INSTALLATION	ADJUSTMENT	CODE
Folding/ Feathering/ Out of Aperture	0	5
Solid 2-blade in aperture	0	5
Outboard retracted when racing	0	m
Vertical Shaft Drive (Sail Drive)	0	s
Outboard not retracted	+3	k
Solid 2-blade out of aperture	+6	4
Solid 3-blade in aperture	+6	3
Solid 3-blade out of aperture	+12	2
Non-standard (as estimated by handicapper)		1

C. JIB

Adjustment is based on the largest jib and determined by the LP/J ratio stated as a percent.

LP/J PERCENT	ADJUSTMENT	CODE
195.1 & over	-15	b
185.1-195	-12	9
175.1-185	-9	8
165.1-175	-6	7
155.1-165	-3	6
145.1-155	0	5
135.1-145	+3	4
Up to 135	+6	3

NOTE: No headsail may be set to extend aft of the LP line used to establish the handicap.

D. SPINNAKER

Adjustment is normally* based on the largest spinnaker and determined by the SMW/J ratio stated as a percent.

SPIN	ADJUSTMENT	CODE
228.1 and over	-12	9
213.1-228	-9	8
198.1-213	-6	7
183.1-198	-3	6
168.1-183	0	5

*NOTE: If the spinnaker pole (SPL) is greater than J then the SPIN % is the greater of SMW/J or 1.8 x SPL/J.